

TRALERT® YPSILON SERIES (ART. WD-12080.1)

Features:

- 8000 lumens
- Driving beam
- Duo-colour daytime running lights
- 30cm +300cm extension cable
- Deutsch connector
- 9-36V multivoltage
- 120 Watts
- Dimensions: ø229 x 69mm
- 12V - 10A / 24V - 5A
- 10 lux at 123m / 1 lux at 460m

- E CE
- R10 IP68
- R148 R149
- 3Y

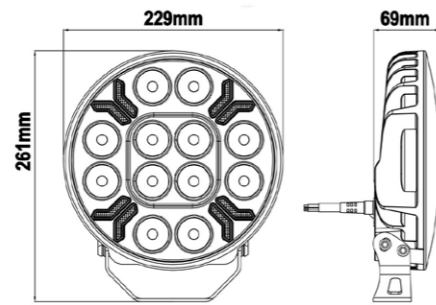

TRALERT® PHANTOM SERIES (ART. WD-16016)

Features:

- 16000 lumens
- Driving beam
- Duo-colour daytime running lights
- 300cm cable
- Deutsch connector
- 9-36V multivoltage
- 160 Watts
- 220 x 205 x 74mm
- 12V - 13.3A / 24V - 6.6A
- 1 lux at 667m

- E CE
- R10 IP68
- R148 R149
- 3Y

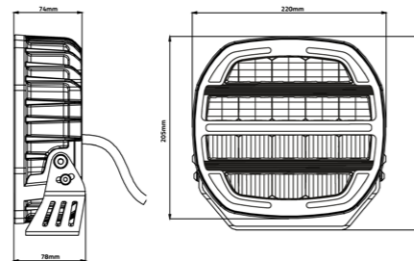

TRALERT® EDGE SERIES (ART. WR-2428.1)

Features:

- 2800 lumens
- Flood beam / R23 reversing light
- 200cm cable + Deutsch connector
- 9-36V multivoltage
- 4x 6W LEDs
- Dimensions: 130 x 42 x 56mm
- 1.60A at 12v / 0.80A at 24v
- 34 lux at 10m / 1 lux at 59m
- Beam angle 70°
- Two mounting angles available

- E CE
- R10 R23
- IP69K CSPR 25 C3
- 2Y

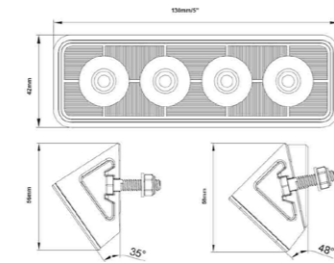

TRALERT® EDGE SERIES (ART. WF-6056)

Features:

- 5600 lumens
- Flood beam
- Built-in Deutsch-connector
- 9-36V multivoltage
- 6x 10W LEDs
- Dimensions: 137 x 90 x 67.5mm
- 4.12A at 12v / 2.1A at 24v
- 76 lux at 10m / 1 lux at 88m
- Beam angle 3x 120°
- Unique arrangement of the LEDs

- E CE
- R10 CSPR 25 C5
- IP69K 2Y

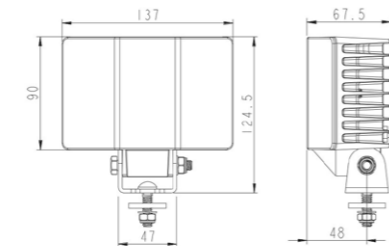

TRALERT® ONIX SERIES (ART. WF-3027)

Features:

- 2880 lumens
- Flood beam
- 40cm cable
- Deutsch-connector
- 9-10V multivoltage (36V peak resistant)
- 6x 5W LEDs
- Dimensions: 157 x 43.7 x 60mm
- 64 lux at 10m / 1 lux at 73m
- Slimline design
- Dark-look lens

- E CE
- R10 IP69K
- 2Y

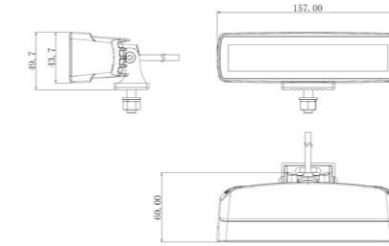

TRALERT® VC-2000 SERIES (ART. VC-2001 & VC-2002)

Features:

- VC-2001: left side
- VC-2002: rear side
- Neon-look LED rear light
- Dynamic indicator
- Brake light
- Reverse light
- Fog light
- Triangular reflector
- 200cm cable, open wire end
- Dimensions: 360 x 135 x 35.5mm

- E CE
- R10 IP69K
- R3 R6
- R7 R38
- R23 3Y

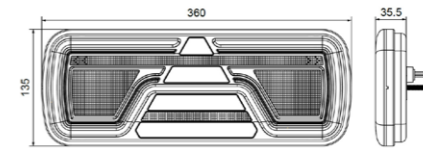

TRALERT® VC-7000 SERIES (ART. VC-7001 & VC-7002)

Features:

- VC-7001: left side
- VC-7002: rear side
- Canbus-proof LED rear light
- Indicator
- Brake light
- Reverse light
- Fog light
- Triangular reflector
- 250cm cable, open wire end
- Dimensions: 450 x 138 x 72.3mm

- E CE
- R10 IP69K
- R3 R6
- R7 R38
- R23 2Y

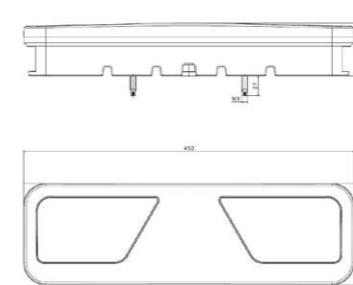

TRALERT® MB-6000 SERIES (ART. MB-6000RWA)

Features:

- Side: universal
- Compact side marker light
- Red, white and amber light colour
- 50cm cable, open wire end
- 12-24V multivoltage
- Dimensions: 97 x 105 x 50mm
- 78mm centre distance

- E CE
- R10 IP68
- R7 R91
- 2Y

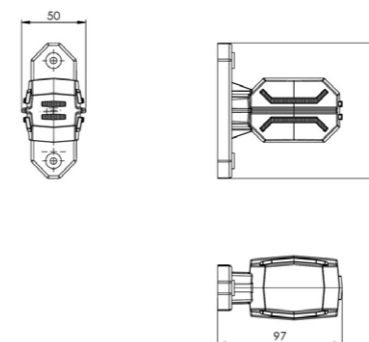

TRALERT® MB-6000 SERIES (ART. MB-6001RWA & MB-6002RWA)

Features:

- MB-6001RWA: left side
- MB-6002RWA: right side
- Red, white and amber light colour
- 50cm cable, open wire end
- 12-24V multivoltage
- Dimensions: 200 x 179 x 50mm
- 78mm centre distance

- E CE
- R10 IP68
- R7 R91
- 2Y

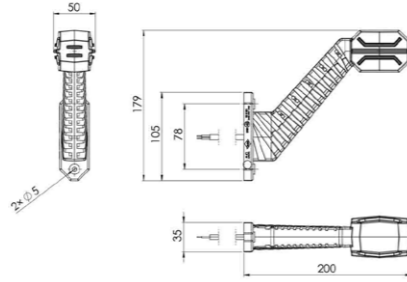

TRALERT® MV-7100 SERIES (ART. MV-7100W)

Features:

- LED top light
- White lens
- White light colour
- 15cm cable, open wire end
- 24V
- Dimensions: 94 x 51 x 62mm
- 61mm centre distance

- E CE
- R10 R7
- IP67 2Y
- IP67



TRALERT® MK-1800 SERIES (ART. MK-1800)

Features:

- Licence plate holder
- Integrated LED licence plate lights
- Fully certified
- 150cm cable, open wire end
- 12-24V multivoltage
- 550 x 145.7 x 37.2mm
- Various mounting holes

- E CE
- R10 R148
- IP68 2Y

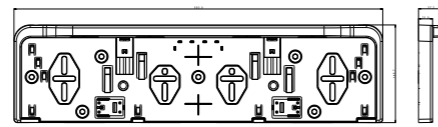

TRALERT® MV-3300 SERIES (ART. MV-3300A, MV-3300R & MV-3300W)

Features:

- MV-3300A: amber colour
- MV-3300R: red colour
- MV-3300W: white colour
- 50cm cable, open wire end
- 12-24V multivoltage
- Dimensions: 122 x 44 x 16mm
- 66mm or 92mm centre distance

- E CE
- R10 R3
- R9 IP68
- 2Y



TRALERT® MV-2400 SERIES (ART. MV-2400A.1, MV-2400R.1 & MV-2400W.1)

Features:

- MV-2400A.1: amber colour
- MV-2400R.1: red colour
- MV-2400W.1: white colour
- 15cm cable, open wire end
- 12-24V multivoltage
- Dimensions: 84.2 x 27.7 x 12.8mm
- 58mm centre distance
- 2 rubber housings included

- E CE
- R10 R3
- R9 IP68
- 2Y

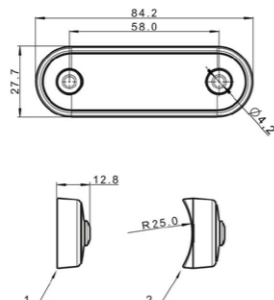

TRALERT®: YOUR PARTNER IN LED VEHICLE LIGHTING.

TRALERT® is the specialist partner in high-quality LED lighting solutions for commercial vehicles. Designed for professionals who value reliability, safety and appearance, TRALERT® delivers a comprehensive range of LED vehicle lighting for trucks, semi-trailers and other commercial or industrial vehicles.

From individual lighting components to complete plug-and-play lighting kits, TRALERT® offers solutions that are easy to install, fully certified and tailored to professional use. Supported by Truck Parts North Wales, TRALERT® stands for consistent quality, technical expertise and a professional presence on the road.

By combining robust engineering with practical, vehicle-oriented design, TRALERT® enables operators and drivers to work more efficiently, safely and with confidence. All products are developed to meet stringent quality and certification standards, ensuring dependable performance in demanding working conditions.

